



# CURVA DE FLANGE MÓVEL COM PÉ A 90° MOVABLE FLANGED 90° DUCKFOOT BEND

10.1004

PN 10 / 16 / 25

construção seg. according to	EN 545:2006
Flange	DIN EN 1092-2

componente	material	component	material	norma	standard
corpo e flanges	ferro fundido dúctil (EN-GJS-500)	body and flanges	ductile iron (EN-GJS-500)	DIN EN 1563	
revestimento anticorrosivo interior e exterior	tinta epóxica potável RESICOAT 9000 R4 BLUE aplicada electrostaticamente com espessura $\geq 250 \mu\text{m}$	coating inside and outside	epoxy paint potable RESICOAT 9000 R4 BLUE applied electrostatically with thickness $\geq 250 \mu\text{m}$	DIN 30677	

**Sob Consulta:**  
Outros diâmetros.

**On request:**  
Other diameters.

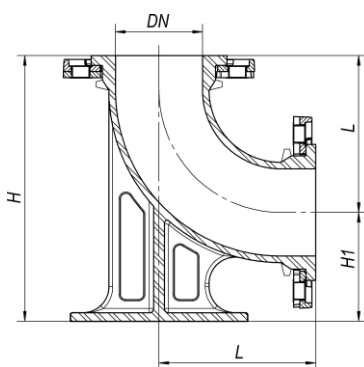

DN	Código - Code			L	H	H1	Peso - Weight (Kg)		
	PN 10	PN 16	PN 25				PN 10	PN 16	PN 25
40	10001015	10001015	10001515	140	227	87	8.0	8.0	8.0
50	10001025	10001025	10001525	150	245	95	9.0	9.0	9.0
60	10001035	10001035	10001535	165	265	100	12.0	12.0	12.0
65	10001045	10001045	10001545	165	265	100	12.0	12.0	12.0
80	10001055	10001055	10001555	165	275	110	12.8	12.8	12.8
100	10001065	10001065	10001565	180	305	125	16.0	16.0	16.8
125	10001076	10001076	10001575	200	340	140	20.0	20.0	20.8
150	10001079	10001079	10001585	220	380	160	26.0	26.0	26.8
200	10001087	10001087	10001595	260	450	190	38.0	38.0	39.4
250	10001092	10001092	10001605	350	575	225	65.0	65.0	67.6
300	10001097	10001100	10001615	400	655	255	94.0	94.0	98.4
350	10001105	10001110	10001625	450	740	290	134.0	136.8	148.0
400	10001125	10001130	10001635	500	820	320	181.0	186.8	198.0
500	10001135	10001140	10001655	600	985	385	253.0	270.4	283.0
600	10001145	10001148	10001665	700	1150	450	344.0	364.0	380.0



### Homologações - Homologation

#### Revestimento - Coating

- INETI (Portugal)
- KIWA (Holanda - Netherlands)
- WRAS (Reino Unido - United Kingdom)
- CARSO (França - France)
- HYGIENE Institut Ruhrgebiets (Alemanha - Germany)

Sendo um dos principais objectivos da nossa empresa o desenvolvimento e aperfeiçoamento dos nossos produtos, reservamo-nos no direito de fornecer quaisquer outros que possam diferir ligeiramente dos descritos e ilustrados nesta publicação.

Being one of our aims a constant development of our products, the characteristics of described material may be altered without prior warning.