

# A-A

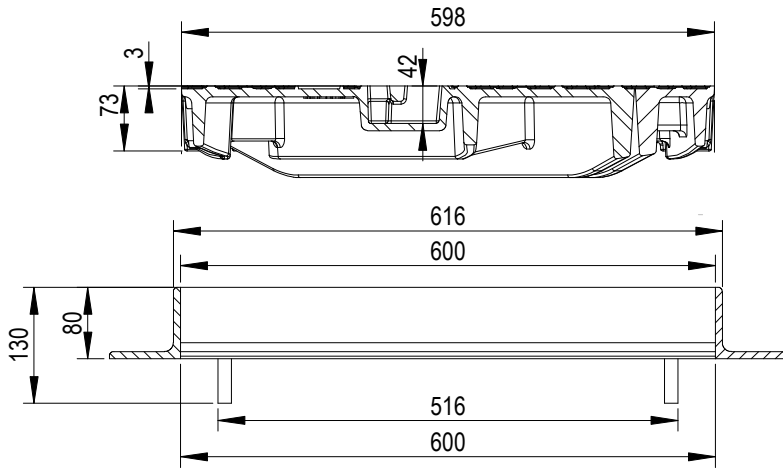

PERFIL T  
80x80x9

CANTONEIRA  
80x8

# B-B

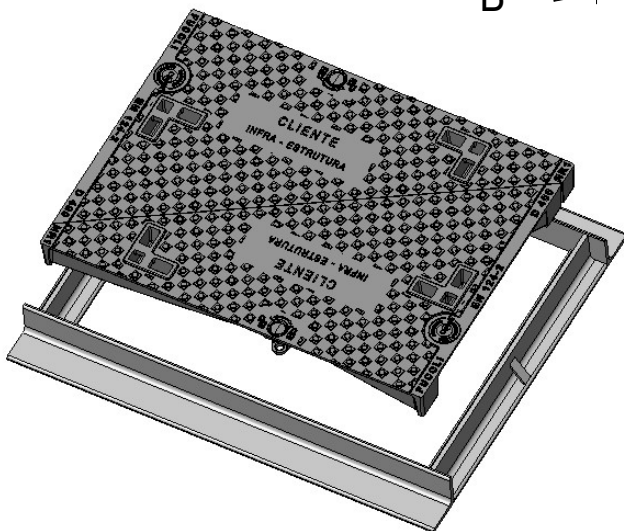
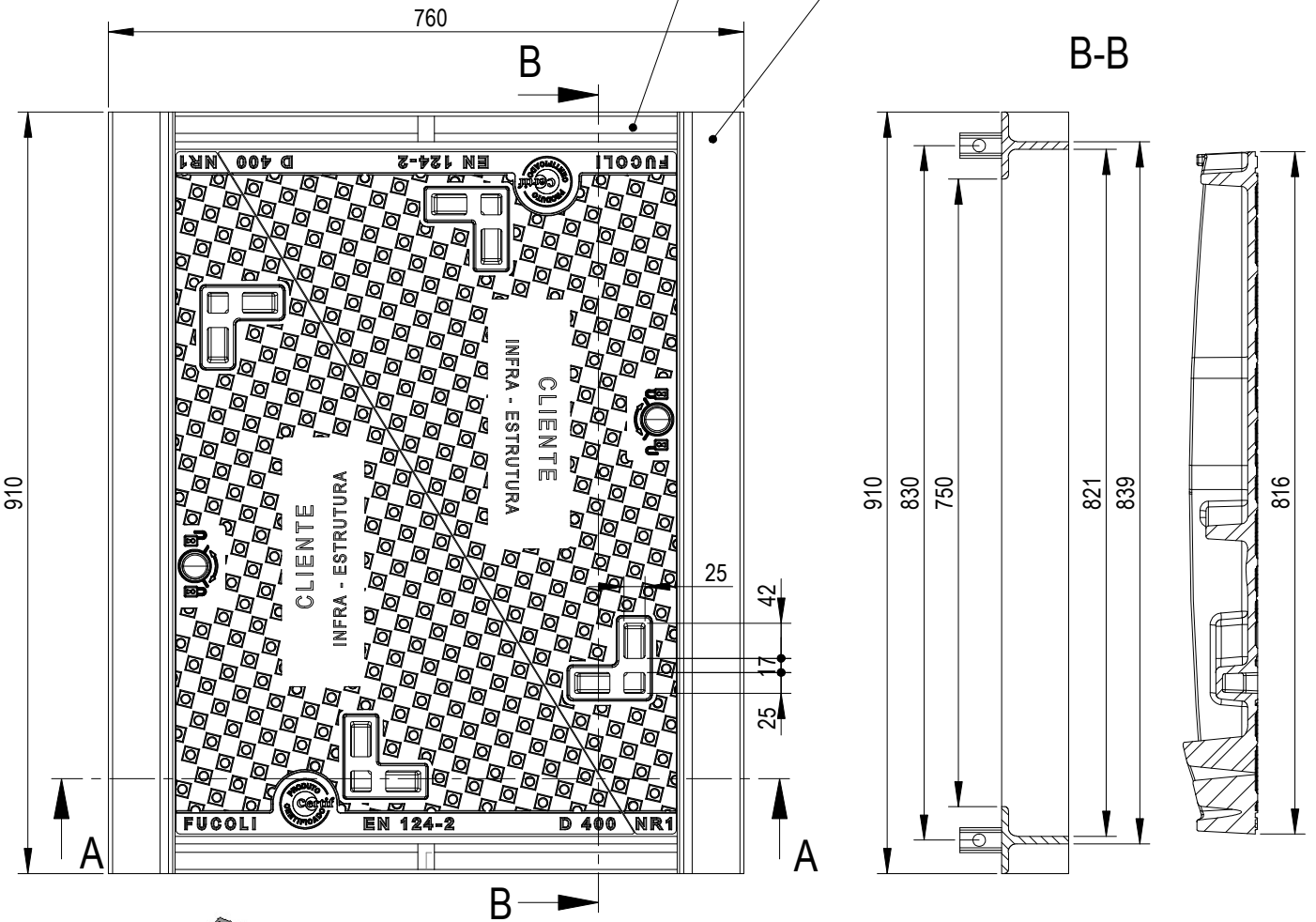

## DESIGNAÇÃO

### ARO+TAMPA RECT. 750x600 D400 NR1 N T/TELECOM



COMPONENTE	PESO (Kg)	CARACTERÍSTICAS	DESENHO Nº
TAMPA TRIANGULAR 750x600 D400 NR1 T/TELECOM [204.18.111]	2x39,6	RELEVO TAMPA 25,6 %	<b>204.18.110</b>
ARO RECT. 750x600 D400 NR1 T/TELECOM GS [204.18.112]	30,4	COTA DE PASSAGEM 600 mm	
		SUP. APOIO DO ARO 1,66 N/mm <sup>2</sup>	TOLER. ISO 8062-3 DCTG9
			REV. Nº DATA
			5 31/07/2020

Os pesos apresentados podem ter uma variação e são dados a nível indicativo sem valor contratual.