

# FLANGED SOFT SEALING GATE VALVE S15 3000

## DN 40 - 600 PN10/16

01.201



### Product description

- Flanged soft sealing gate valve series 3000 for drinking water and neutral liquids
- Service temperature from 0°C (excluding frost) to 70°C

### Standards

- Designed according to EN 1074 part 1 & 2 and EN 1171
- Flange drilling to EN 1092-2 PN10/16
- Face-to-face according to EN 558 series 15

### Tests

All valves are individually hydrostatically tested according to EN 1074-1/2 and EN 12266:

- Seal 1.1 x PN (in bar); Body: 1.5 x PN (in bar). Operation torque test

### Corrosion protection

- Epoxy powder coating RAL 5005
- Applied internal and external with a minimum coating thickness of 250 µm
- Potable water approved epoxy coating, fusion bonded according to DIN 3476-1, EN 14901 and GSK approved

### Approvals

- Certified according to EN 1074-1/2: KIWA Certificate K76981/01 and AENOR Certificate B18/000002
- ACS Potability Certificate 15 ACC NY 005
- GSK Epoxy Coating Certificate GSK-ID:1247 (RAL-GZ 662)

### Features

- Isolation valve approved for drinking water
- Full bore
- Low operating torque
- The valves from DN 250 to DN 300 are equipped with an axial bearing, from DN 350 to DN 600 are equipped with two thrust bearings to ensure reduced operating torque
- Stainless steel stem with rolled threads produced by cold rolling process, which keeps the steel structure and increase its mechanical resistance
- Stem sealing system with 4 O-rings in EPDM
- O-ring stem sealing exchangeable under pressure
- Wedge fully vulcanized with drinking water approved EPDM
- Top of the wedge conceived with “soft stop” system, which acts as an end stop for the fully open valve
- Wedge with brass nut fixed in the wedge core preventing vibration and ensure a long life span
- Wedge and body designed with “monorail” system
- Round EPDM bonnet gasket fixed in a recess, surrounding the bolts, ensuring a perfect seal
- Body/bonnet bolts in stainless steel A2 encased and sealed ensuring full corrosion protection
- Accessories: handwheel [ref.05.100], stem cap [ref. 05.200], extension spindle [ref. 05.300] and surface box [ref. 05.500]
- On request possibility of stem in stainless steel AISI 316L, NBR sealings and wedge nut in different brass grades.



**Fucoli Somepal**  
FUNDAÇÃO DE FERRO, S. A.

Visit our website at [www.fucoli-somepal.pt](http://www.fucoli-somepal.pt)

Head office: Estrada de Coselhas, 3000-125 Coimbra – Portugal | Tel.: (+351) 239 490100 | Fax: (+351) 239 490198

Branch office: Rua de Aveiro 50, 3050-420 Pampilhosa – Portugal | Tel.: (+351) 239 490100 | Fax: (+351) 231 949292 | [comercial@fucoli-somepal.pt](mailto:comercial@fucoli-somepal.pt)

# FLANGED SOFT SEALING GATE VALVE S15 3000

## DN 40 - 600 PN10/16

01.201

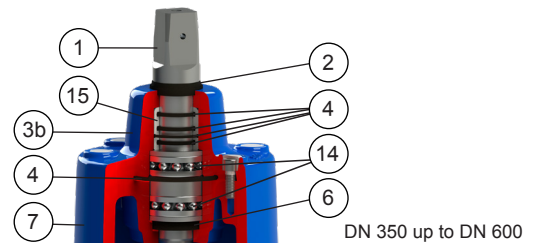
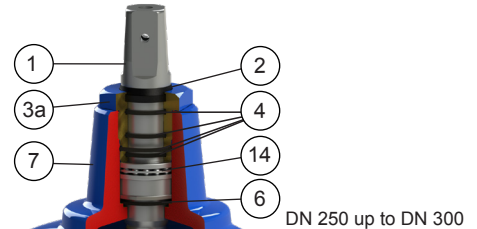
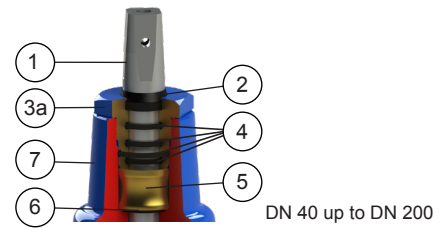
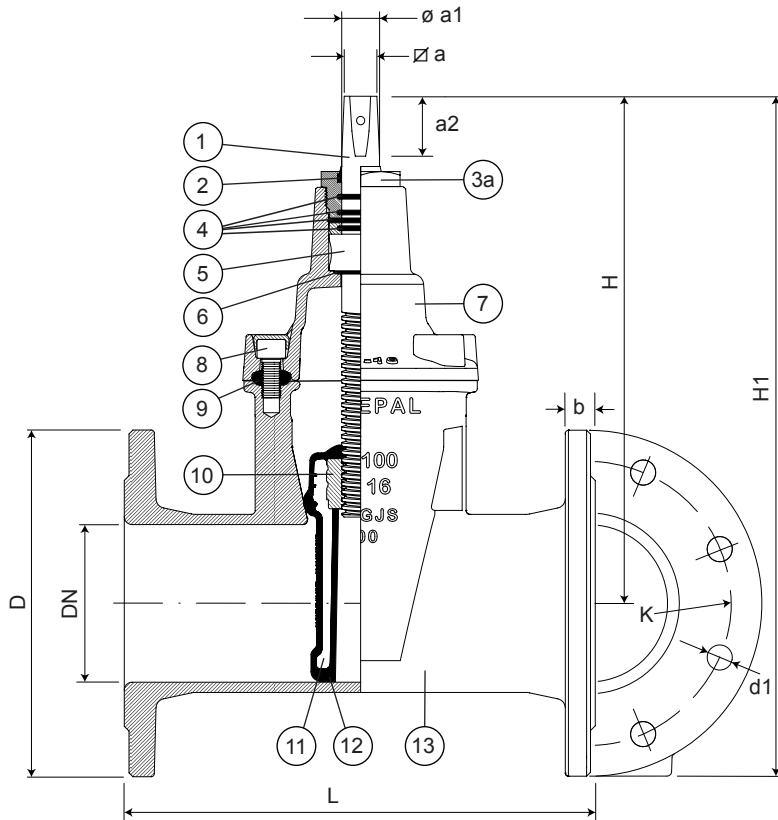

### Component list

pos.	components	material	standard
1	Stem	Stainless steel AISI 420	EN 10088 - 1
2	Clearing joint	Elastomer	
3a	Gland	Brass DZR CW602N	EN 12164
3b	Gland	Ductile iron EN-GJS-500-7	EN 1563
4	O-rings	Elastomer EPDM	EN 681 - 1
5	Stem washer	Brass DZR CW602N	EN 12164
6	O-ring	Elastomer EPDM	EN 681 - 1
7	Bonnet	Ductile iron EN-GJS-500-7	EN 1563

pos.	components	material	standard
8	Bolts	Stainless steel A2	EN 10088 - 1
9	Bonnet gasket	Elastomer EPDM	EN 681 - 1
10	Wedge nut	Brass DZR CW626N	EN 12164
11	Wedge	Ductile iron EN-GJS-500-7	EN 1563
12	Wedge covering	Elastomer EPDM	EN 681 - 1
13	Body	Ductile iron EN-GJS-500-7	EN 1563
14	Bearing	Steel	ISO 20516
15	Gland bush	POM	

### Reference and dimensions

DN	PN	code	D	L	H	H1	K	n° x d1	b	$\varnothing a$	$\varnothing a1$	a2	turns to open	Kg approx.
			mm	mm	mm	mm	mm	mm	mm	mm	mm	mm		
40	10/16	10712014	150	240	203	278	110	4 x 19	19	14.1	20	29	10	8
50	10/16	10712024	165	250	235	318	125	4 x 19	19	14.1	20	29	13	11
60	10/16	10712034	175	270	250	338	135	4 x 19	19	17.1	22	34	13	13
65	10/16	10712044	185	270	250	343	145	4 x 19	19	17.1	22	34	13	13
80	10/16	10712054	200	280	290	390	160	8 x 19	19	17.1	22	34	16	17
100	10/16	10712064	220	300	325	435	180	8 x 19	19	19.1	24	38	20	21
125	10/16	10712074	250	325	362	487	210	8 x 19	19	19.1	26	38	25	26
150	10/16	10712084	285	350	425	568	240	8 x 23	19	19.1	28	38	30	38
200	10	10712094	340	400	505	675	295	8 x 23	20	24.1	32	42	34	54
200	16	10712097	340	400	505	675	295	12 x 23	20	24.1	32	42	34	54
250	10	10712104	400	450	595	795	350	12 x 23	22	27.1	36	47	42	80
250	16	10712110	400	450	595	795	355	12 x 28	22	27.1	36	47	42	80
300	10	10712114	455	500	670	898	400	12 x 23	24.5	27.1	36	47	50	132
300	16	10712120	455	500	670	898	410	12 x 28	24.5	27.1	36	47	50	132
350	10	10712124	505	550	940	1193	460	16 x 23	24.5	32.1	45	55	67	254

continued on next page

# FLANGED SOFT SEALING GATE VALVE S15 3000 DN 40 - 600 PN10/16

01.201



continued from previous page

DN	PN	code	D mm	L mm	H mm	H1 mm	K mm	n° x d1 mm	b mm	∅ a mm	∅ a1 mm	a2 mm	turns to open	Kg approx.
350	16	10712130	520	550	940	1200	470	16 x 28	26.5	32.1	45	55	67	258
400	10	10712134	565	600	940	1223	515	16 x 28	24.5	32.1	45	55	67	277
400	16	10712140	580	600	940	1230	525	16 x 31	28	32.1	45	55	67	280
450	10	10712144	615	650	1120	1428	565	20 x 28	25.5	32.1	50	55	71	448
450	16	10712150	640	650	1120	1440	585	20 x 31	30	32.1	50	55	71	465
500	10	10712154	670	700	1120	1455	620	20 x 28	26.5	32.1	50	55	71	482
500	16	10712160	715	700	1120	1478	650	20 x 34	31.5	32.1	50	55	71	499
600	10	10712164	780	800	1290	1680	725	20 x 31	30	41.1	60	74	86	639
600	16	10712170	840	800	1290	1710	770	20 x 37	36	41.1	60	74	86	689



**Fucoli Somepal**  
FUNDAÇÃO DE FERRO, S.A.

Visit our website at [www.fucoli-somepal.pt](http://www.fucoli-somepal.pt)

**Head office:** Estrada de Coselhas, 3000-125 Coimbra – Portugal | Tel.: (+351) 239 490100 | Fax: (+351) 239 490198

**Branch office:** Rua de Aveiro 50, 3050-420 Pampilhosa – Portugal | Tel.: (+351) 239 490100 | Fax: (+351) 231 949292 | [comercial@fucoli-somepal.pt](mailto:comercial@fucoli-somepal.pt)

