

FLANGED SOFT SEALING GATE VALVE S14 3000

with AUMA electric actuator

DN 40 - 500 PN10/16

11.102A



Product description

- Flanged soft sealing gate valve series 3000 with AUMA electric actuator for waste water
- Face-to-face length – S14
- Service temperature from 0°C (excluding frost) to 70°C

Standards

- Designed according to EN 1074 parte 1 & 2 and EN 1171
- Flange drilling to EN 1092-2 PN10/16
- Face-to-face according to EN 558 serie 14
- ISO top flange according to ISO 5210
- Auma Norm multi-turn electric actuators with enclosure IP68 according to EN 60529

Tests

All valves are individually hydrostatically tested according to EN 1074-1/2 and EN 12266:

- Seal 1.1 x PN (in bar); Body: 1.5 x PN (in bar)

Corrosion protection

- Epoxy powder coating RAL 3011
- Applied internal and external with a minimum coating thickness of 250 µm
- Fusion bonded epoxy coating according DIN 3476-1, EN 14901 and GSK (RAL-GZ662) guidelines

Features

- Isolation valve for waste water with full bore
- The valves from DN 250 to DN 300 are equipped with an axial bearing, from DN 350 to DN 500 are equipped with two thrust bearings to ensure reduced operating torque
- Stainless steel stem with rolled threads produced by cold rolling process, which keeps the steel structure and increase its mechanical resistance
- Stem sealing system with 4 O-rings in NBR, exchangeable under pressure
- Wedge fully vulcanized with NBR
- Wedge with brass nut fixed in the wedge core preventing vibration and ensure a long life span
- Wedge and body designed with “monorail” system
- Round NBR bonnet gasket fixed in a recess, surrounding the bolts, ensuring a perfect seal
- Body/bonnet bolts in stainless steel A2 encased and sealed ensuring full corrosion protection
- Auma Norm electric actuator multi-turn SA with three-phase AC motors (3PH - 400V - 50Hz - IP68)
- On request possibility of actuator Auma Norm single phase, Auma Matic, Aumatic or others.



Fucoli Somepal
FUNDAÇÃO DE FERRO, S. A.

Visit our website at www.fucoli-somepal.pt

Head office: Estrada de Coselhas, 3000-125 Coimbra – Portugal | Tel.: (+351) 239 490100 | Fax: (+351) 239 490198

Branch office: Rua de Aveiro 50, 3050-420 Pampilhosa – Portugal | Tel.: (+351) 239 490100 | Fax: (+351) 231 949292 | comercial@fucoli-somepal.pt

FLANGED SOFT SEALING GATE VALVE S14 3000

with AUMA electric actuator
DN 40 - 500 PN10/16

11.102A

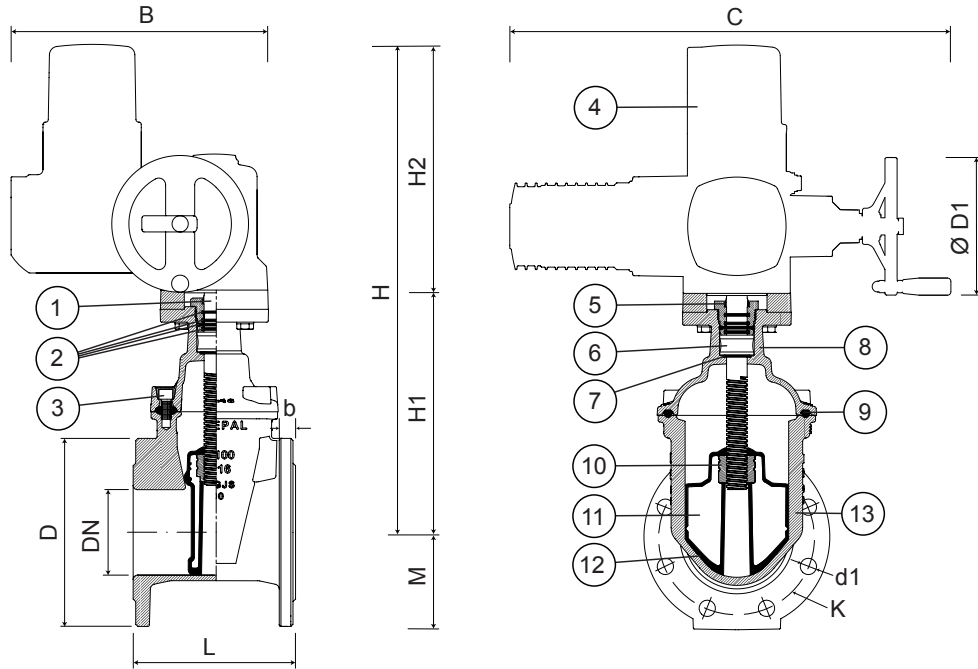

Component list

pos.	components	material	standard
1	Stem	Stainless stell AISI 316L	EN 10088 - 1
2	O-rings	Elastomer NBR	EN 681 - 1
3	Bolts	Stainless stell A2	EN 10088 - 1
4	AUMA electric actuator		
5	Clearing joint	Elastomer	
6	Stem washer	Brass	EN 12164
7	O-rings	Elastomer NBR	EN 681 - 1

pos.	components	material	standard
8	Bonnet	Ductile iron EN-GJS-500-7	EN 1563
9	Bonnet gasket	Elastomer NBR	EN 681 - 1
10	Wedge nut	Brass	EN 12164
11	Wedge	Ductile iron EN-GJS-500-7	EN 1563
12	Wedge covering	Elastomer NBR	EN 681 - 1
13	Body	Ductile iron EN-GJS-500-7	EN 1563

Reference and dimensions

DN	PN	code	D	L	H	H1	M	K	n° x d1	b	ISO 5210 flange	AUMA actuator	B	C	Ø D1	H2	RPM actuator	closed time s.	Kg approx.
40	10/16	10725800A	150	140	496	208	75	110	4 x 19	19	F10	SA 07.6	300	514	160	288	45	17	35
50	10/16	10725810A	165	150	496	208	83	125	4 x 19	19	F10	SA 07.6	300	514	160	288	45	17	37
60	10/16	10725820A	175	170	505	217	88	135	4 x 19	19	F10	SA 07.6	300	514	160	288	45	18	39
65	10/16	10725830A	185	170	505	217	93	145	4 x 19	19	F10	SA 07.6	300	514	160	288	45	18	43
80	10/16	10725840A	200	180	545	257	100	160	8 x 19	19	F10	SA 07.6	300	514	160	288	45	22	44
100	10/16	10725850A	220	190	576	286	110	180	8 x 19	19	F10	SA 10.2	313	537	200	290	45	27	51
125	10/16	10725860A	250	200	613	323	125	210	8 x 19	19	F10	SA 10.2	313	537	200	290	45	34	56
150	10/16	10725870A	285	210	674	384	143	240	8 x 23	19	F10	SA 10.2	313	537	200	290	45	40	64
200	10	10725880A	340	230	749	459	115	295	8 x 23	20	F10	SA 10.2	313	537	200	290	45	45	81
200	16	10725885A	340	230	749	459	115	295	12 x 23	20	F10	SA 10.2	313	537	200	290	45	45	81
250	10	10725890A	400	250	861	545	200	350	12 x 23	22	F14	SA 14.2	377	725	315	316	22	114	136
250	16	10725895A	400	250	861	545	200	355	12 x 28	22	F14	SA 14.2	377	725	315	316	22	114	136
300	10	10725900A	455	270	936	620	228	400	12 x 23	24.5	F14	SA 14.2	377	725	315	316	22	137	166
300	16	10725905A	455	270	936	620	228	410	12 x 28	24.5	F14	SA 14.2	377	725	315	316	22	137	169
350	10	10725910A	505	290	1191	875	253	460	16 x 23	24.5	F14	SA 14.6	377	728	400	316	22	156	283
350	16	10725915A	520	290	1191	875	260	470	16 x 28	26.5	F14	SA 14.6	377	728	400	316	22	156	287
400	10	10725920A	565	310	1191	875	283	515	16 x 28	24.5	F14	SA 14.6	377	728	400	316	22	156	301
400	16	10725925A	580	310	1191	875	290	525	16 x 31	28	F14	SA 14.6	377	728	400	316	22	156	307
450	10	10725930A	615	330	1371	1055	308	565	20 x 28	25.5	F14	SA 14.6	377	728	400	316	22	171	451
450	16	10725935A	640	330	1371	1055	320	585	20 x 31	30	F14	SA 14.6	377	728	400	316	22	171	459
500	10	10725940A	670	350	1371	1055	335	620	20 x 28	26.5	F14	SA 14.6	377	728	400	316	22	171	475
500	16	10725945A	715	350	1371	1055	358	650	20 x 34	31.5	F14	SA 14.6	377	728	400	316	22	171	492

Electric actuator with RPMs other than those mentioned, on request. For more information on the electric actuator consult the manufacturer's technical documentation.