

# SPIGOT END SOFT SEALING GATE VALVE 3000

## DN 50 - 500 PN16

01.301



### Product description

- Spigot end soft sealing gate valve series 3000 for drinking water and neutral liquids
- Service temperature from 0°C (excluding frost) to 70°C

### Standards

- Designed according to EN 1074 part 1 & 2 and EN 1171

### Tests

All valves are individually hydrostatically tested according to EN 1074-1/2 and EN 12266:

- Seal 1.1 x PN (in bar); Body: 1.5 x PN (in bar). Operation torque test

### Corrosion protection

- Epoxy powder coating RAL 5005
- Applied internal and external with a minimum coating thickness of 250 µm
- Potable water approved epoxy coating, fusion bonded according DIN 3476,-1 EN 14901 and GSK approved

### Approvals

- Certified according to EN 1074-1/2: AENOR Certificate B18/000002
- ACS Potability Certificate 15 ACC NY 005
- GSK Epoxy Coating Certificate GSK-ID:1247 (RAL-GZ 662)

### Features

- Isolation valve approved for drinking water
- Full bore
- Low operating torque
- The valves from DN 250 to DN 300 are equipped with an axial bearing, from DN 350 to DN 500 are equipped with two thrust bearings to ensure reduced operating torque
- Stainless steel stem with rolled threads produced by cold rolling process, which keeps the steel structure and increase its mechanical resistance
- Stem sealing system with 4 O-rings in EPDM
- O-ring stem sealing exchangeable under pressure
- Wedge fully vulcanized with drinking water approved EPDM
- Top of the wedge conceived with “soft stop” system, which acts as an end stop for the fully open valve
- Wedge with brass nut fixed in the wedge core preventing vibration and ensure a long life span
- Wedge and body designed with “monorail” system
- Round EPDM bonnet gasket fixed in a recess, surrounding the bolts, ensuring a perfect seal
- Body/bonnet bolts in stainless steel A2 encased and sealed ensuring full corrosion protection
- Accessories: handwheel [ref.05.100], stem cap [ref. 05.200], extension spindle [ref. 05.300] and surface box [ref. 05.500]
- On request possibility of stem in stainless steel AISI 316L, NBR sealings and wedge nut in different brass grades.



**Fucoli Somepal**  
FUNDAÇÃO DE FERRO, S. A.

Visit our website at [www.fucoli-somepal.pt](http://www.fucoli-somepal.pt)

Head office: Estrada de Coselhas, 3000-125 Coimbra – Portugal | Tel.: (+351) 239 490100 | Fax: (+351) 239 490198

Branch office: Rua de Aveiro 50, 3050-420 Pampilhosa – Portugal | Tel.: (+351) 239 490100 | Fax: (+351) 231 949292 | [comercial@fucoli-somepal.pt](mailto:comercial@fucoli-somepal.pt)

# SPIGOT END SOFT SEALING GATE VALVE 3000 DN 50 - 500 PN16

01.301

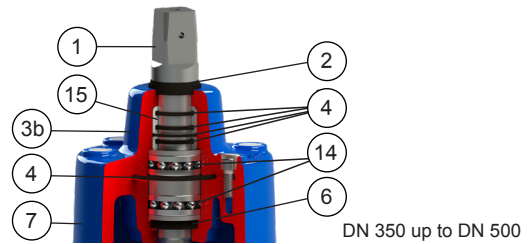
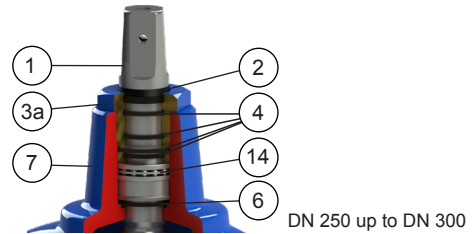
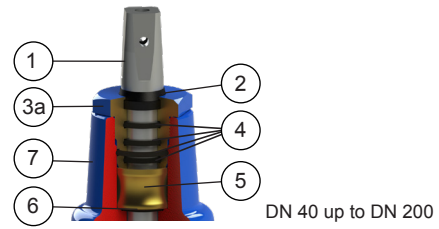
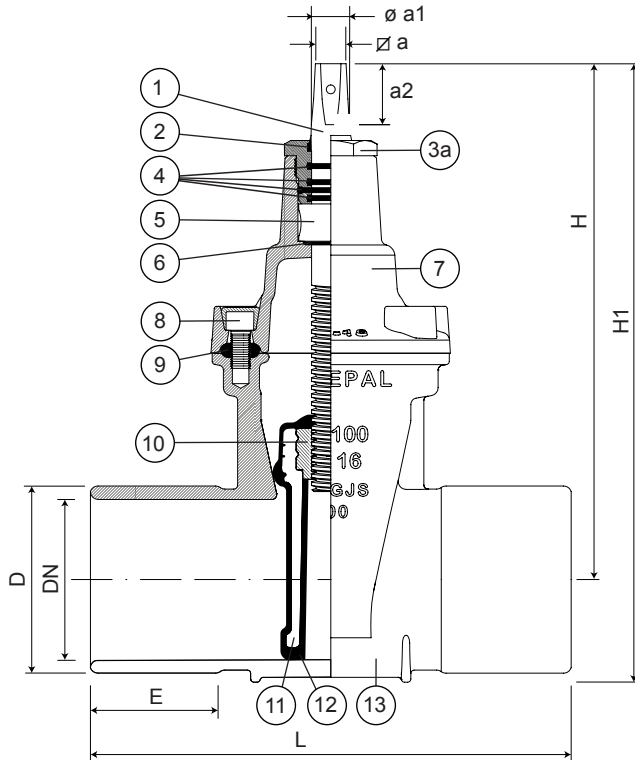

## Component list

pos.	components	material	standard
1	Stem	Stainless steel AISI 420	EN 10088 - 1
2	Clearing joint	Elastomer	
3a	Gland	Brass DZR CW602N	EN 12164
3b	Gland	Ductile iron EN-GJS-500-7	EN 1563
4	O-rings	Elastomer EPDM	EN 681 - 1
5	Stem washer	Brass DZR CW602N	EN 12164
6	O-ring	Elastomer EPDM	EN 681 - 1
7	Bonnet	Ductile iron EN-GJS-500-7	EN 1563

pos.	components	material	standard
8	Bolts	Stainless steel A2	EN 10088 - 1
9	Bonnet gasket	Elastomer EPDM	EN 681 - 1
10	Wedge nut	Brass DZR CW626N	EN 12164
11	Wedge	Ductile iron EN-GJS-500-7	EN 1563
12	Wedge covering	Elastomer EPDM	EN 681 - 1
13	Body	Ductile iron EN-GJS-500-7	EN 1563
14	Bearing	Steel	ISO 20516
15	Gland bush	POM	

## Reference and dimensions

DN	code	D class 18	L mm	E min	H mm	H1 mm	∅ a mm	∅ a1 mm	a2 mm	turns to open	Kg approx.
50	10723010	65	250	72	235	272	14.1	20	29	13	7
60	10723020	76	270	72	250	295	17.1	22	34	13	9
65	10723025	82	270	72	250	295	17.1	22	34	13	9
80	10723030	96	280	74	290	342	17.1	22	34	16	12
100	10723040	118	300	80	325	390	19.1	24	38	20	16
100	10723043	118	600	230	325	390	19.1	24	38	20	24
125	10723050	145	325	96	362	442	19.1	26	38	25	20
150	10723060	174	350	100	425	520	19.1	28	38	30	31
150	10723063	174	600	225	425	520	19.1	28	38	30	48
200	10723070	228	400	110	505	628	24.1	32	42	34	48
250	10723080	282	450	128	595	745	27.1	36	47	42	70
300	10723090	338	500	145	670	850	27.1	36	47	50	113
350	10723100	396	550	145	940	1180	32.1	45	55	67	260
400	10723110	452	600	145	940	1180	32.1	45	55	67	278
450	10723120	512	650	145	1120	1415	32.1	50	55	71	470
500	10723130	568	700	150	1120	1415	32.1	50	55	71	509



**Fucoli Somepal**  
FUNDAÇÃO DE FERRO, S.A.

Visit our website at [www.fucoli-somepal.pt](http://www.fucoli-somepal.pt)

Head office: Estrada de Coselhas, 3000-125 Coimbra - Portugal | Tel.: (+351) 239 490100 | Fax: (+351) 239 490198

Branch office: Rua de Aveiro 50, 3050-420 Pampilhosa - Portugal | Tel.: (+351) 239 490100 | Fax: (+351) 231 949292 | [comercial@fucoli-somepal.pt](mailto:comercial@fucoli-somepal.pt)



100% MADE IN EUROPE