

SOFT SEALING GATE VALVE WITH PE PIPES SPIGOT ENDS 3000

PE100 PN16 SDR11 pipe end

DN 50 - 400 PN16

01.501



Product description

- Soft sealing gate valve with PE spigot ends series 3000 for drinking water and neutral liquids
- Service temperature from 0°C (excluding frost) to 40°C

Standards

- Designed according to EN 1074 part 1 & 2 and EN 1171
- PE 100 PN16 SDR11 pipe according to EN 12201-2

Tests

All valves are individually hydrostatically tested according to EN 1074-1/2 and EN 12266:

- Seal 1.1 x PN (in bar); Body: 1.5 x PN (in bar). Operation torque test

Corrosion protection

- Epoxy powder coating RAL 5005
- Applied internal and external with a minimum coating thickness of 250 µm
- Potable water approved epoxy coating, fusion bonded according DIN 3476-1, EN 14901 and GSK approved

Approvals

- Certified according to EN 1074-1/2: AENOR Certificate B18/000002
- ACS Potability Certificate 15 ACC NY 005
- GSK Epoxy Coating Certificate GSK-ID:1247 (RAL-GZ 662)

Features

- Isolation valve for drinking water with full bore
- Low operating torque
- The valves from DN 250 to DN 300 are equipped with an axial bearing, DN 400 are equipped with two thrust bearings to ensure reduced operating torque
- Stainless steel stem with rolled threads produced by cold rolling process, which keeps the steel structure and increase its mechanical resistance
- Stem sealing system with 4 O-rings in EPDM
- O-ring stem sealing exchangeable under pressure
- Wedge fully vulcanized with drinking water approved EPDM
- Top of the wedge conceived with “soft stop” system, which acts as an end stop for the fully open valve
- Wedge with brass nut fixed in the wedge core preventing vibration and ensure a long life span
- Wedge and body designed with “monorail” system
- Round EPDM bonnet gasket fixed in a recess, surrounding the bolts, ensuring a perfect seal
- Body/bonnet bolts in stainless steel A2 encased and sealed ensuring full corrosion protection
- PE100 PN16 SDR11 pipe end that allow a perfect butt fusion and electrofusion with the PE pipeline
- The PE pipe is pressed onto the grooved valve end body and blocked with a cast iron sleeve and sealed with plastic shrink hose
- Accessories: handwheel [ref.05.100], stem cap [ref. 05.200], extension spindle [ref. 05.300] and surface box [ref. 05.500]
- On request possibility of stem in stainless steel AISI 316L, NBR sealings and wedge nut in different brass grades.



Fucoli Somepal
FUNDAÇÃO DE FERRO, S. A.

Visit our website at www.fucoli-somepal.pt

Head office: Estrada de Coselhas, 3000-125 Coimbra – Portugal | Tel.: (+351) 239 490100 | Fax: (+351) 239 490198

Branch office: Rua de Aveiro 50, 3050-420 Pampilhosa – Portugal | Tel.: (+351) 239 490100 | Fax: (+351) 231 949292 | comercial@fucoli-somepal.pt

SOFT SEALING GATE VALVE WITH PE PIPES SPIGOT ENDS 3000

PE100 PN16 SDR11 pipe end

DN 50 - 400 PN16

01.501

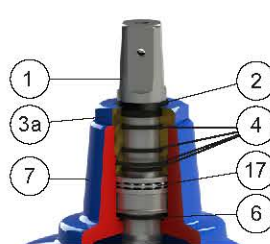
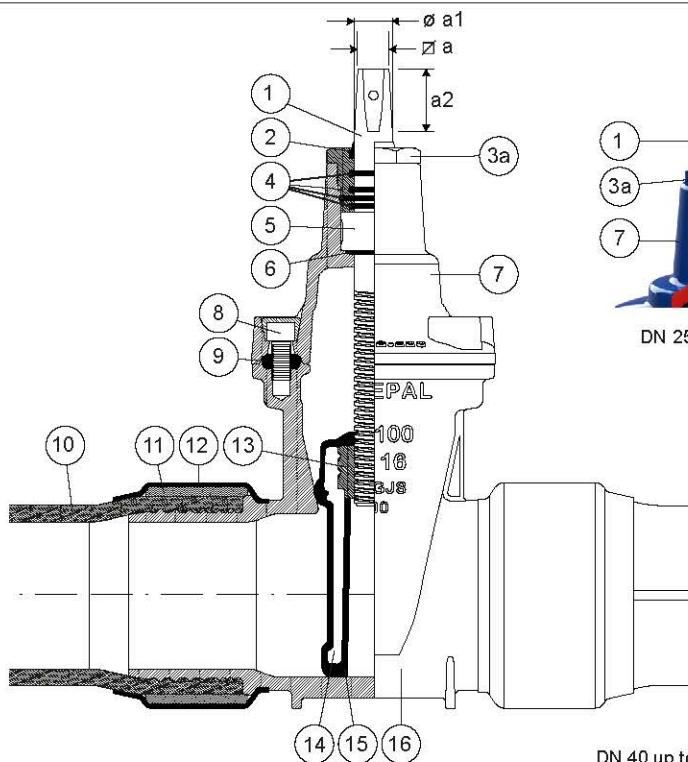

DN 250 up to DN 300

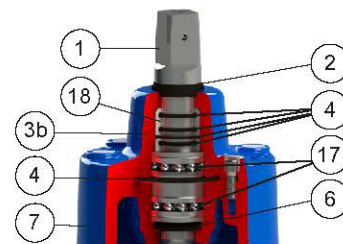

DN 400

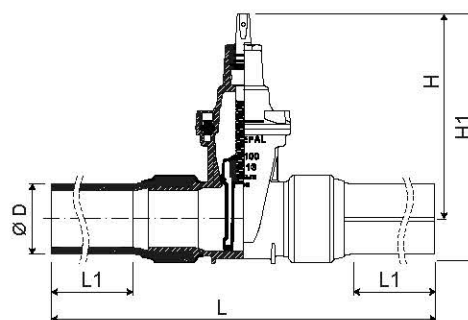

DN 40 up to DN 200

Component list

pos.	components	material	standard
1	Stem	Stainless steel AISI 420	EN 10088 - 1
2	Clearing joint	Elastomer	-
3a	Gland	Brass DZR CW602N	EN 12164
3b	Gland	Ductile iron EN-GJS-500-7	EN 1563
4	O-rings	Elastomer EPDM	EN 681 - 1
5	Stem washer	Brass DZR CW602N	EN 12164
6	O-ring	Elastomer EPDM	EN 681 - 1
7	Bonnet	Ductile iron EN-GJS-500-7	EN 1563
8	Bolts	Stainless steel A2	EN 10088 - 1
9	Bonnet gasket	Elastomer EPDM	EN 681 - 1

pos.	components	material	standard
10	Pipe	PE100 PN16 SDR11	EN 12201 - 2
11	Sleeve	Ductile iron EN-GJS-500-7	EN 1563
12	Shrink hose	Plastic	-
13	Wedge nut	Brass DZR CW626N	EN 12164
14	Wedge	Ductile iron EN-GJS-500-7	EN 1563
15	Wedge covering	Elastomer EPDM	EN 681 - 1
16	Body	Ductile iron EN-GJS-500-7	EN 1563
17	Bearing	Steel	ISO 20516
18	Gland bush	POM	-

Reference and dimensions

DN	$\varnothing D$ ext. PE	code	L mm	L1 mm	H mm	H1 mm	$\varnothing a$ mm	$\varnothing a1$ mm	a2 mm	turns to open	Kg approx.
50	63	10750034	680	190	235	276	14.1	20	29	13	9
65	75	10750044	700	190	250	298	17.1	22	34	13	11
80	90	10750054	800	230	290	350	17.1	22	34	16	17
100	110	10750064	800	230	325	395	19.1	24	38	20	21
125	125	10750070	845	240	362	443	19.1	26	38	25	26
125	140	10750080	845	240	362	451	19.1	26	38	25	35
150	160	10750090	900	250	425	527	19.1	28	38	30	40
150	180	10750100	900	250	425	527	19.1	28	38	30	50
200	200	10750110	1050	285	505	628	24.1	32	42	34	69
200	225	10750120	1050	285	505	642	24.1	32	42	34	70
250	250	10750130	1100	285	595	744	27.1	36	47	42	94
250	280	10750140	1100	285	595	745	27.1	36	47	42	129
300	315	10750150	1300	330	670	850	27.1	36	47	50	156
300	355	10750155	1300	330	670	890	27.1	36	47	50	175
400	400	10750160	1400	330	940	1180	32.1	45	55	67	335



Fucoli Somepal
FUNDAÇÃO DE FERRO, S.A.

Visit our website at www.fucoli-somepal.pt

Head office: Estrada de Coselhas, 3000-125 Coimbra – Portugal | Tel.: (+351) 239 490100 | Fax: (+351) 239 490198

Branch office: Rua de Aveiro 50, 3060-420 Pampilhosa – Portugal | Tel.: (+351) 239 490100 | Fax: (+351) 231 949292 | comercial@fucoli-somepal.pt



100% MADE IN EUROPE