

# FLANGED SOFT SEALING GATE VALVE S14 3000

## with AUMA electric actuator

### DN 40 - 600 PN10/16

01.102A



#### Product description

- Flanged soft sealing gate valve series 3000 with AUMA electric actuator for drinking water and neutral liquids
- Face-to-face length – S14
- Service temperature from 0°C (excluding frost) to 70°C

#### Standards

- Designed according to EN 1074 parte 1 & 2 and EN 1171
- Flange drilling to EN 1092-2 PN10/16
- Face-to-face according to EN 558 serie 14
- ISO top flange according to ISO 5210
- Auma Norm multi-turn electric actuators with enclosure IP68 according to EN 60529

#### Tests

All valves are individually hydrostatically tested according to EN 1074-1/2 and EN 12266:

- Seal 1.1 x PN (in bar); Body: 1.5 x PN (in bar)

#### Corrosion protection

- Epoxy powder coating RAL 5005
- Applied internal and external with a minimum coating thickness of 250 µm
- Potable water approved epoxy coating, fusion bonded according DIN 3476-1, EN 14901 and GSK approved

#### Approvals

- ACS Potability Certificate 15 ACC NY 005
- GSK Epoxy Coating Certificate GSK-ID:1247 (RAL-GZ 662)

#### Features

- Isolation valve approved for drinking water with full bore
- The valves from DN 250 to DN 300 are equipped with an axial bearing, from DN 350 to DN 600 are equipped with two thrust bearings to ensure reduced operating torque
- Stainless steel stem with rolled threads produced by cold rolling process, which keeps the steel structure and increase its mechanical resistance
- Stem sealing system with 4 O-rings in EPDM, exchangeable under pressure
- Wedge fully vulcanized with drinking water approved EPDM
- Wedge with brass nut fixed in the wedge core preventing vibration and ensure a long life span
- Wedge and body designed with “monorail” system
- Round EPDM bonnet gasket fixed in a recess, surrounding the bolts, ensuring a perfect seal
- Body/bonnet bolts in stainless steel A2 encased and sealed ensuring full corrosion protection
- Auma Norm electric actuator multi-turn SA with three-phase AC motors (3PH - 400V - 50Hz - IP68)
- On request possibility of stem in stainless steel AISI 316L, NBR sealings, wedge nut in different brass grades, actuator Auma Norm single phase, Auma Matic, Aumatic or others.



DEUTSCHE ZERTIFIZIERUNGSGESellschaft  
VON ANLAGEN UND FORTSCHRITTEN



**Fucoli Somepal**  
FUNDAÇÃO DE FERRO, S. A.

Visit our website at [www.fucoli-somepal.pt](http://www.fucoli-somepal.pt)

**Head office:** Estrada de Coselhas, 3000-125 Coimbra – Portugal | Tel.: (+351) 239 490100 | Fax: (+351) 239 490198

**Branch office:** Rua de Aveiro 50, 3050-420 Pampilhosa – Portugal | Tel.: (+351) 239 490100 | Fax: (+351) 231 949292 | [comercial@fucoli-somepal.pt](mailto:comercial@fucoli-somepal.pt)

# FLANGED SOFT SEALING GATE VALVE S14 3000

with AUMA electric actuator

DN 40 - 600 PN10/16

01.102A

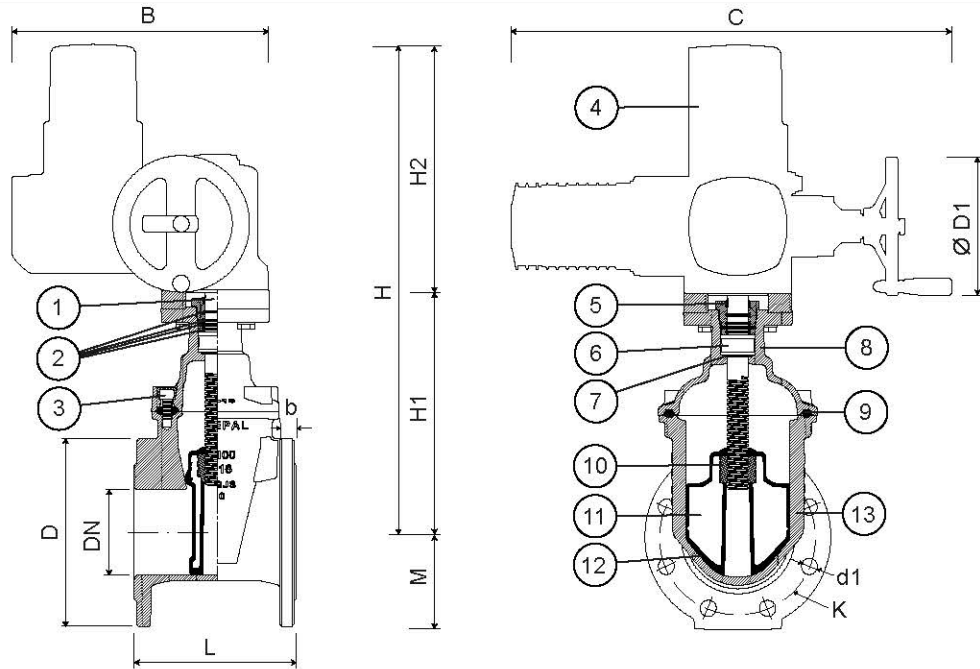

## Component list

pos.	components	material	standard
1	Stern	Stainless stell AISI 420	EN 10088 - 1
2	O-rings	Elastomer EPDM	EN 681 - 1
3	Bolts	Stainless stell A2	EN 10088 - 1
4	AUMA electric actuator		
5	Clearing joint	Elastomer	
6	Stern washer	Brass DZR CW602N	EN 12164
7	O-rings	Elastomer EPDM	EN 681 - 1

pos.	components	material	standard
8	Bonnet	Ductile iron EN-GJS-500-7	EN 1563
9	Bonnet gasket	Elastomer EPDM	EN 681 - 1
10	Wedge nut	Brass DZR CW626N	EN 12164
11	Wedge	Ductile iron EN-GJS-500-7	EN 1563
12	Wedge covering	Elastomer EPDM	EN 681 - 1
13	Body	Ductile iron EN-GJS-500-7	EN 1563

## Reference and dimensions

DN	PN	code	D	L	H	H1	M	K	n° x d1	b	ISO 5210 flange	AUMA actuator	B	C	Ø D1	H2	RPM actuator	closed time s.	Kg approx.
40	10/16	10725500A	150	140	496	208	75	110	4 x 19	19	F10	SA 07.6	300	514	160	288	45	17	35
50	10/16	10725510A	165	150	496	208	83	125	4 x 19	19	F10	SA 07.6	300	514	160	288	45	17	37
60	10/16	10725520A	175	170	505	217	88	135	4 x 19	19	F10	SA 07.6	300	514	160	288	45	18	39
65	10/16	10725530A	185	170	505	217	93	145	4 x 19	19	F10	SA 07.6	300	514	160	288	45	18	43
80	10/16	10725540A	200	180	545	257	100	160	8 x 19	19	F10	SA 07.6	300	514	160	288	45	22	44
100	10/16	10725550A	220	190	576	286	110	180	8 x 19	19	F10	SA 10.2	313	537	200	290	45	27	51
125	10/16	10725560A	250	200	613	323	125	210	8 x 19	19	F10	SA 10.2	313	537	200	290	45	34	56
150	10/16	10725570A	285	210	674	384	143	240	8 x 23	19	F10	SA 10.2	313	537	200	290	45	40	64
200	10	10725580A	340	230	749	459	115	295	8 x 23	20	F10	SA 10.2	313	537	200	290	45	45	81
200	16	10725585A	340	230	749	459	115	295	12 x 23	20	F10	SA 10.2	313	537	200	290	45	45	81
250	10	10725590A	400	250	861	545	200	350	12 x 23	22	F14	SA 14.2	377	725	315	316	22	114	136
250	16	10725595A	400	250	861	545	200	355	12 x 28	22	F14	SA 14.2	377	725	315	316	22	114	136
300	10	10725600A	455	270	936	620	228	400	12 x 23	24.5	F14	SA 14.2	377	725	315	316	22	137	166
300	16	10725605A	455	270	936	620	228	410	12 x 28	24.5	F14	SA 14.2	377	725	315	316	22	137	169
350	10	10725610A	505	290	1191	875	253	460	16 x 23	24.5	F14	SA 14.6	377	728	400	316	22	183	283
350	16	10725615A	520	290	1191	875	260	470	16 x 28	26.5	F14	SA 14.6	377	728	400	316	22	183	287
400	10	10725620A	565	310	1191	875	283	515	16 x 28	24.5	F14	SA 14.6	377	728	400	316	22	183	301
400	16	10725625A	580	310	1191	875	290	525	16 x 31	28	F14	SA 14.6	377	728	400	316	22	183	307
450	10	10725630A	615	330	1371	1055	308	565	20 x 28	25.5	F14	SA 14.6	377	728	400	316	22	171	451
450	16	10725635A	640	330	1371	1055	320	585	20 x 31	30	F14	SA 14.6	377	728	400	316	22	171	459

Electric actuator with RPMs other than those mentioned, on request. For more information on the electric actuator consult the manufacturer's technical documentation.

continued on next page

**FLANGED SOFT SEALING GATE VALVE S14 3000**  
**with AUMA electric actuator**  
**DN 40 - 600 PN10/16**

01.102A



continued from previous page

DN	PN	code	D	L	H	H1	M	K	n° x d1	b	ISO 5210 flange	AUMA actuator	B	C	Ø D1	H2	RPM actuator	closed time s.	Kg approx.
			mm	mm	mm	mm	mm	mm	mm	mm			mm	mm	mm	mm			
500	10	10725640A	670	350	1371	1055	335	620	20 x 28	26.5	F14	SA 14.6	377	728	400	316	22	171	475
500	16	10725645A	715	350	1371	1055	358	650	20 x 34	31.5	F14	SA 14.6	377	728	400	316	22	171	492
600	10	10725650A	780	390	1550	1210	390	725	20 x 31	30	F16	SA 16.2	422	795	500	340	22	205	-
600	16	10725655A	840	390	1550	1210	420	770	20 x 37	36	F16	SA 16.2	422	795	500	340	22	205	-

Electric actuator with RPMs other than those mentioned, on request.  
 For more information on the electric actuator consult the manufacturer's technical documentation.



**Fucoli Somepal**  
 FUNDAÇÃO DE FERRO, S. A.

Visit our website at [www.fucoli-somepal.pt](http://www.fucoli-somepal.pt)

**Head office:** Estrada de Coselhas, 3000-125 Coimbra – Portugal | Tel.: (+351) 239 490100 | Fax: (+351) 239 490198

**Branch office:** Rua de Aveiro 50, 3050-420 Pampilhosa – Portugal | Tel.: (+351) 239 490100 | Fax: (+351) 231 949292 | [comercial@fucoli-somepal.pt](mailto:comercial@fucoli-somepal.pt)

