

SOFT SEALING GATE VALVE SOCKET ENDS FOR UPVC 3000 DN 40 - 400 PN16

01.401



Product description

- Soft sealing gate valve with socket ends for uPVC pipes series 3000 for drinking water and neutral liquids
- Service temperature from 0°C (excluding frost) to 70°C

Standards

- Designed according to EN 1074 part 1 & 2 and EN 1171
- For PVC pipes according to EN ISO 1452-2

Tests

All valves are individually hydrostatically tested according to EN 1074-1/2 and EN 12266:

- Seal 1.1 x PN (in bar); Body: 1.5 x PN (in bar). Operation torque test

Corrosion protection

- Epoxy powder coating RAL 5005
- Applied internal and external with a minimum coating thickness of 250 µm
- Potable water approved epoxy coating, fusion bonded according DIN 3476-1, EN 14901 and GSK approved

Approvals

- Certified according to EN 1074-1/2: AENOR Certificate B18/000002
- ACS Potability Certificate 15 ACC NY 005
- GSK Epoxy Coating Certificate GSK-ID:1247 (RAL-GZ 662)

Features

- Isolation valve approved for drinking water
- Full bore
- Low operating torque
- The valves from DN 250 to DN 300 are equipped with an axial bearing, DN 400 is equipped with two thrust bearings to ensure reduced operating torque
- Stainless steel stem with rolled threads produced by cold rolling process, which keeps the steel structure and increase its mechanical resistance
- Stem sealing system with 4 O-rings in EPDM
- O-ring stem sealing exchangeable under pressure
- Wedge fully vulcanized with drinking water approved EPDM
- Top of the wedge conceived with "soft stop" system, which acts as an end stop for the fully open valve
- Wedge with brass nut fixed in the wedge core preventing vibration and ensure a long life span
- Wedge and body designed with "monorail" system
- Round EPDM bonnet gasket fixed in a recess, surrounding the bolts, ensuring a perfect seal
- Body/bonnet bolts in stainless steel A2 encased and sealed ensuring full corrosion protection
- Suitable for PVC piper
- Socket ends with EPDM double lip seal ring to ensure a perfect sealing
- Accessories: handwheel [ref.05.100], stem cap [ref. 05.200], extension spindle [ref. 05.300] and surface box [ref. 05.500]
- On request possibility of stem in stainless steel AISI 316L, NBR sealings and wedge nut in different brass grades.



Fucoli Somepal
FUNDAÇÃO DE FERRO, S. A.

Visit our website at www.fucoli-somepal.pt

Head office: Estrada de Coselhas, 3000-125 Coimbra – Portugal | Tel.: (+351) 239 490100 | Fax: (+351) 239 490198

Branch office: Rua de Aveiro 50, 3050-420 Pampilhosa – Portugal | Tel.: (+351) 239 490100 | Fax: (+351) 231 949292 | comercial@fucoli-somepal.pt

SOFT SEALING GATE VALVE SOCKET ENDS FOR UPVC 3000 DN 40 - 400 PN16

01.401

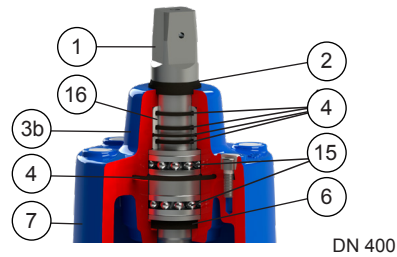
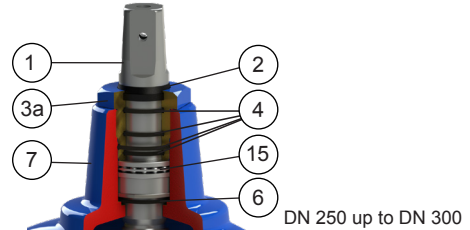
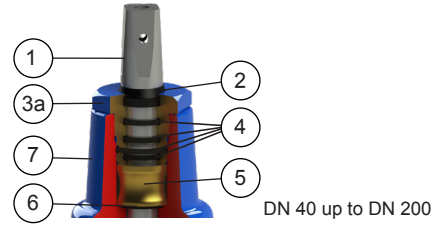
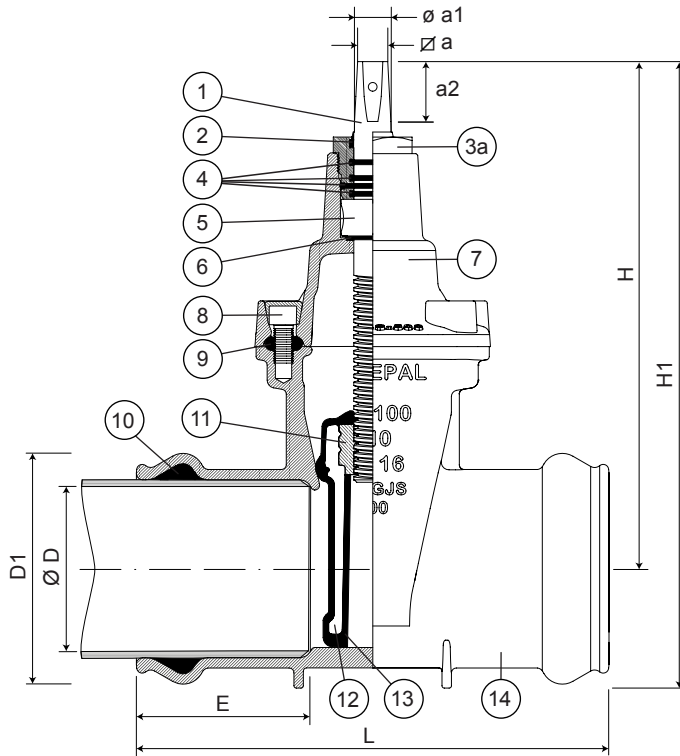

Component list

pos.	components	material	standard
1	Stem	Stainless steel AISI 420	EN 10088 - 1
2	Clearing joint	Elastomer	
3a	Gland	Brass DZR CW602N	EN 12164
3b	Gland	Ductile iron EN-GJS-500-7	EN 1563
4	O-rings	Elastomer EPDM	EN 681 - 1
5	Stem washer	Brass DZR CW602N	EN 12164
6	O-ring	Elastomer EPDM	EN 681 - 1
7	Bonnet	Ductile iron EN-GJS-500-7	EN 1563

pos.	components	material	standard
8	Bolts	Stainless steel A2	EN 10088 - 1
9	Bonnet gasket	Elastomer EPDM	EN 681 - 1
10	Lip seal ring	Elastomer EPDM	EN 681 - 1
11	Wedge nut	Brass DZR CW602N	EN 12164
12	Wedge	Ductile iron EN-GJS-500-7	EN 1563
13	Wedge covering	Elastomer EPDM	EN 681 - 1
14	Body	Ductile iron EN-GJS-500-7	EN 1563
15	Bearing	Steel	ISO 20516
16	Gland bush	POM	

Reference and dimensions

DN	Ø D ext. PVC	code	D1 mm	L mm	E min	H mm	H1 mm	Ø a mm	Ø a1 mm	a2 mm	turns to open	Kg approx.
40	50	10720994	74	220	76	234	274	14.1	20	29	13	7
50	63	10721004	93	250	91	235	285	14.1	20	29	13	7
65	75	10721014	106	270	99	250	305	17.1	22	34	13	9
80	90	10721024	124	280	102	290	355	17.1	22	34	20	13
100	110	10721034	147	300	111	325	400	19.1	24	38	20	16
125	125	10721044	161	325	117	362	445	19.1	26	38	25	19
125	140	10721054	178	325	117	362	455	19.1	26	38	25	20
150	160	10721064	201	350	117	425	530	19.1	28	38	30	30
200	200	10721074	245	400	137	505	630	24.1	32	42	34	44
200	225	10721069	271	400	135	505	643	24.1	32	42	34	47
250	250	10721084	302	450	150	595	750	27.1	36	47	42	65
300	315	10721094	372	490	166	670	860	27.1	36	47	50	98
400	400	10721104	464	640	195	940	1180	32.1	45	55	67	235



Fucoli Somepal
FUNDAÇÃO DE FERRO, S.A.

Visit our website at www.fucoli-somepal.pt

Head office: Estrada de Coselhas, 3000-125 Coimbra – Portugal | Tel.: (+351) 239 490100 | Fax: (+351) 239 490198

Branch office: Rua de Aveiro 50, 3050-420 Pampilhosa – Portugal | Tel.: (+351) 239 490100 | Fax: (+351) 231 949292 | comercial@fucoli-somepal.pt



100% MADE IN EUROPE